

**CALENDAR ITEM
C06**

A 1
S 1

12/06/16
PRC 5401.1
M.J. Columbus

AMENDMENT OF LEASE AND REVISION OF RENT

LESSEE:

G. Craig Sullivan and Maureen O'Brien Sullivan, Trustees of the Craig and Maureen Sullivan Living Trust dated May 27, 1992

AREA, LAND TYPE, AND LOCATION:

Sovereign land in Lake Tahoe, adjacent to 5526 North Lake Boulevard, near Carnelian Bay, Placer County.

AUTHORIZED USE:

Continued use and maintenance of an existing pier, boat lift, adjustable catwalk, and one mooring buoy.

LEASE TERM:

10 years, beginning February 27, 2012.

CONSIDERATION:

This lease provides that the Commission may modify the rent periodically during the lease term. Pursuant to this provision, staff conducted a review of the rent under this lease and recommends rent be revised from \$1,606 to \$1,021 per year, effective February 27, 2017.

PROPOSED AMENDMENT:

Amend the lease to replace the existing Exhibit A, Land Description, and Exhibit B, Site and Location Map, with the attached Exhibit A, Land Description, and Exhibit B, Site and Location Map (for reference purposes only); revise rent from \$1,606 per year to \$1,021 per year; all other terms and conditions of the lease shall remain in effect without amendment.

STAFF ANALYSIS AND RECOMMENDATION:

Authority:

Public Resources Code sections 6005, 6216, 6301, 6501.1, and 6503.5; California Code of Regulations, title 2, section 2000, subdivision (b).

CALENDAR ITEM NO. **C06** (CONT'D)

Public Trust and the State's Best Interests Analysis:

On December 2, 2013, the Commission authorized a 10-year General Lease – Recreational Use to G. Craig Sullivan and Maureen O'Brien Sullivan, Trustees of the Craig and Maureen Sullivan Living Trust dated May 27, 1992, for an existing pier, boat lift, adjustable catwalk, and one mooring buoy ([Calendar Item C62, December 2, 2013](#)). That lease will expire on February 26, 2022.

Staff conducted the rent review called for in the lease and recommends the rent be revised from \$1,606 to \$1,021 per year based on seasonal use and reduced impact area for the pier and application of the Lake Tahoe Benchmark. Staff also recommends the lease be amended to reflect the new reduced lease (impact) area.

The amendment and revision of rent are lease administrative actions unlikely to result in any changes to the use of the lease premises. The recommended action will not substantially interfere with Public Trust needs at this time and at this location. For these reasons, staff recommends finding the proposed action is in the best interests of the State.

OTHER PERTINENT INFORMATION:

1. This action is consistent with Strategy 2.2 of the Commission's Strategic Plan to ensure timely receipt of revenues and royalties from the use and development of State lands and minerals.
2. Amendment of the lease to make an adjustment in the lease area and the revision of the rent are not projects as defined by the California Environmental Quality Act, because they are administrative actions that will not result in direct or indirect physical changes in the environment.

Authority: Public Resources Code section 21065 and California Code of Regulations, title 14, section 15378, subdivision (b)(5).

EXHIBITS:

- A. Land Description
- B. Site and Location Map

CALENDAR ITEM NO. **C06** (CONT'D)

RECOMMENDED ACTION:

It is recommended that the Commission:

PUBLIC TRUST AND STATE'S BEST INTERESTS:

Find that the proposed amendment and revision or rent of Lease No. PRC 5401.1 will not substantially interfere with the Public Trust needs and values at this location; find these actions are consistent with the common law Public Trust Doctrine and are in the best interests of the State.

AUTHORIZATION:

1. Authorize the amendment of Lease No. PRC 5401.1, a General Lease – Recreational Use, effective February 27, 2017, to replace the existing Exhibit A, Land Description, and Exhibit B, Site and Location Map, with the attached Exhibit A, Land Description, and Exhibit B, Site and Location Map (for reference purposes only).
2. Approve the revision of rent for Lease No. PRC 5401.1 from \$1,606 to \$1,021 per year, effective February 27, 2017; all other terms and conditions of the lease will remain in effect without amendment.

EXHIBIT A

PRC 5401.1

LAND DESCRIPTION

Two parcels of submerged lands situated in the bed of Lake Tahoe, lying adjacent to Lot 3 of fractional Section 15, Township 16 North, Range 17 East, M.D.B.&M., as shown on Official Government Township Plat approved November 10, 1865, County of Placer, State of California, more particularly described as follows:

PARCEL 1- PIER

All those lands underlying an existing pier with adjustable catwalk and boat lift lying adjacent to that parcel described in Grant Deed recorded April 5, 2012 as Document Number 2012-0030062-00 in Official Records of said County.

TOGETHER WITH any applicable Impact Area(s).

EXCEPTING THEREFROM any portion lying landward of elevation 6223 feet LTD on the shoreline of said Lake Tahoe.

PARCEL 2- BUOY

A circular parcel of land, being 50 feet in diameter, underlying an existing buoy lying adjacent to that parcel described in Grant Deed recorded April 5, 2012 as Document Number 2012-0030062-00 in Official Records of said County.

Accompanying plat is hereby made part of this description.

END OF DESCRIPTION

Prepared 09/20/2016 by the California State Lands Commission Boundary Unit.





APN 116-220-052

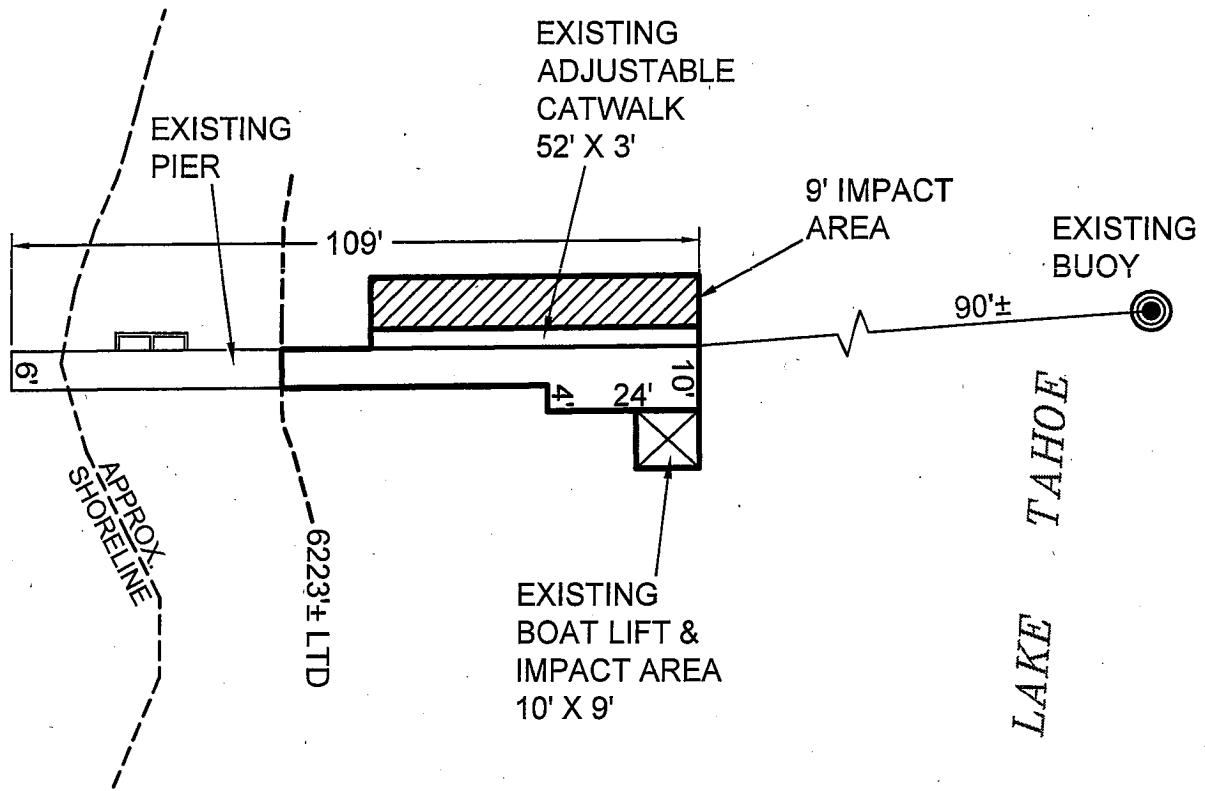

EXHIBIT A

Page 2 of 2

TS 09/20/16

LAND DESCRIPTION PLAT
 PRC 5401.1, SULLIVAN
 PLACER COUNTY

CALIFORNIA STATE
 LANDS COMMISSION



NO SCALE

SITE

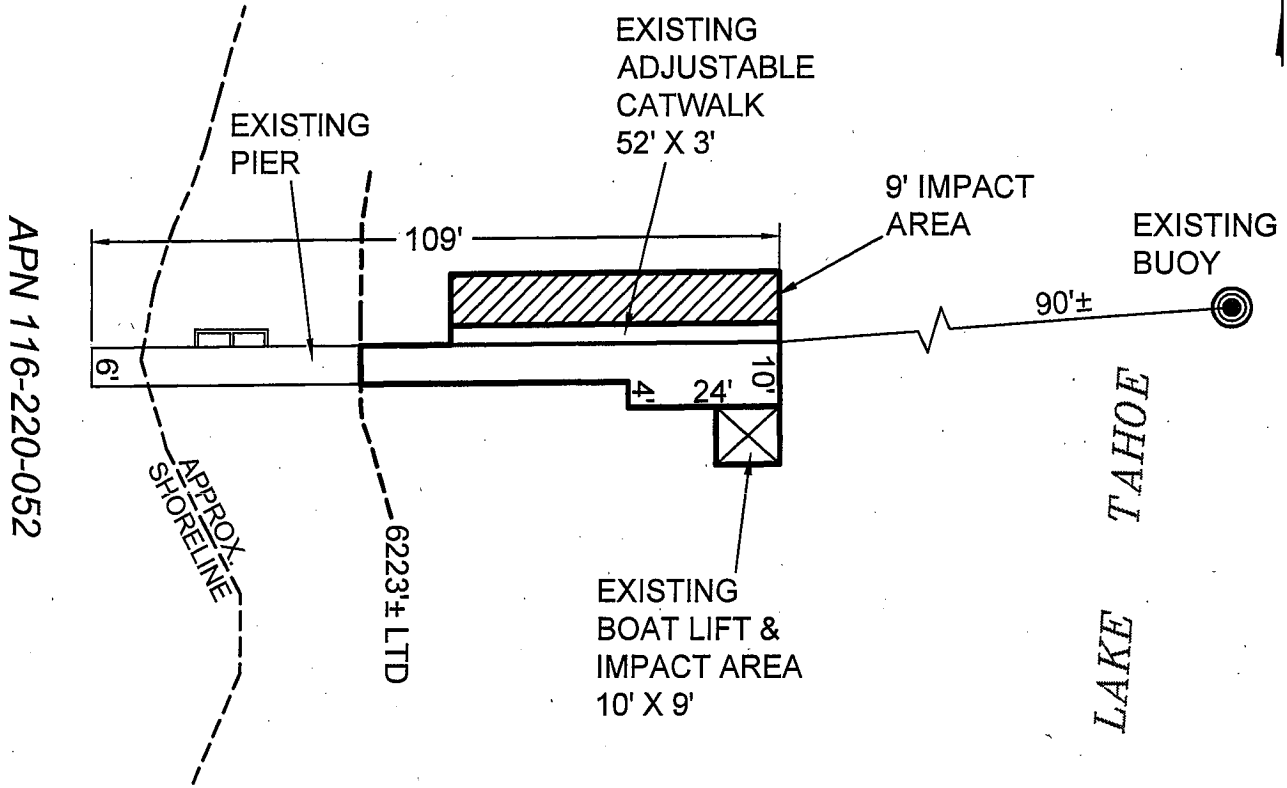

5526 NORTH LAKE BLVD., NEAR CARNELIAN BAY

NO SCALE

LOCATION

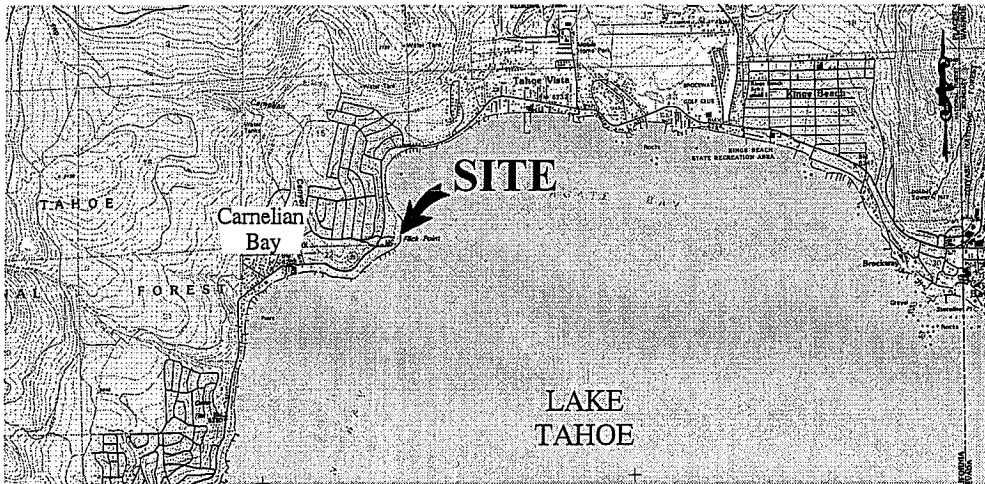

MAP SOURCE: USGS QUAD

This Exhibit is solely for purposes of generally defining the lease premises, is based on unverified information provided by the Lessee or other parties and is not intended to be, nor shall it be construed as, a waiver or limitation of any State interest in the subject or any other property.

Exhibit B

PRC 5401.1
 SULLIVAN
 APN 116-220-052
 GENERAL LEASE -
 RECREATIONAL USE
 PLACER COUNTY

SITE

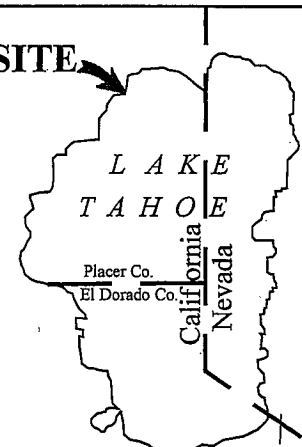

TS 09/20/16